

CAD FILE:

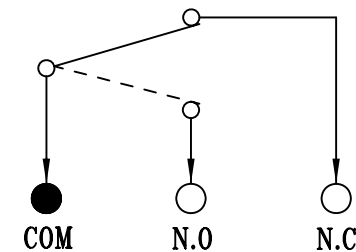

**SCHMATIC**

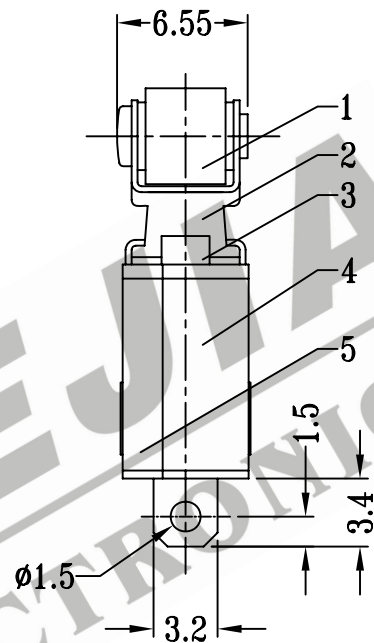
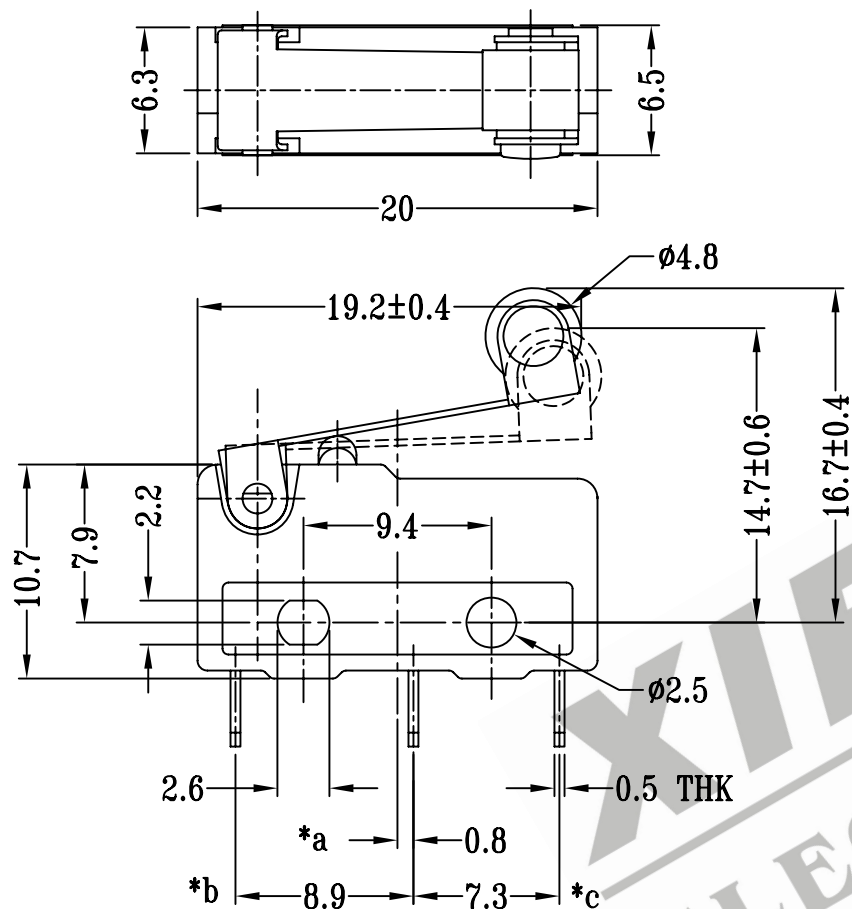
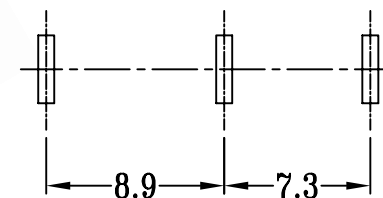

**P.C.B LAYOUT**

注:带"\*"表示关键尺寸(3个)

12	SPRING	SUS WIRE	1	TEMPER
11	CONTACT B	COPPER	1	Ag PLATED
10	CONTACT A	PBS STRIP	1	NATURAL
9	RIVET	ALUMINIUM	1	NATURAL
8	TERMINAL (COM)	BRASS STRIP	1	Ag PLATED OVER Ni PLATED
7	TERMINAL (N.O)	BRASS STRIP	1	Ag PLATED OVER Ni PLATED
6	TERMINAL (N.C)	BRASS STRIP	1	Ag PLATED OVER Ni PLATED
5	COVER	ABS	1	BLACK
4	CASE	ABS	1	BLACK
3	KNOB	ABS	1	RED
2	STEEL KNOB	SUS	1	NATURAL
1	WHEEL	ABS	1	RED
NO.	PARTS	MATERIALS	Q'TY	FINISH

TOLERANCE UNLESS SPECIFIED		SHENZHEN XIEJIA ELECTRONICS CO.,LTD.		
WITHIN: 1.5±0.1mm OVER : 1.5±0.2mm		ISSUE	DATE	DESCRIPTIONS OF REVISION
TITLE : MICRO SWITCH		UNIT : mm		DRWG NO.: XJ-DR-MX98-00
MODEL: MX-98		SCALE: 5 : 2	DWN.	ZHOUYU
ALL MATERIALS MUST BE COMPLIANT TO ROHS		CHK'D	FANGYING	2002-12-2
		APPD.	KANGXINAN	2002-12-2